

SECTION G
ENGINEERING REFERENCE
PART ONE
ENGINEERING NOTES

PART 1 ENGINEERING NOTES

1. INTRODUCTION G-5

- 1.1 Motion Control Systems
- 1.2 Servo Amplifiers
 - 1.2.1 Pulse Width Modulation (PWM)
 - 1.2.2 DC Brush Type Amplifiers
 - 1.2.3 Brushless Amplifiers
- 1.3 Amplifier Modes

2. COMPONENT SELECTION G-10

- 2.1 Motor
- 2.2 Amplifier
- 2.3 Power Supply
- 2.4 Regenerative Operation

PART 2 INSTALLATION NOTES

3. WIRING INSTRUCTIONS G-15

- 3.1 Typical wiring diagrams
- 3.2 Noise considerations and system grounding
- 3.3 DC Power Supply Wiring
- 3.4 Motor Wiring
- 3.5 Tachometer Wiring
- 3.6 Reference Input Wiring
- 3.7 Reference Potentiometer Wiring
- 3.8 Mating signal connectors
- 3.9 CE-EMC Wiring Requirements
- 3.10 CE-LVD Wiring Requirements

4. CAUTIONARY NOTES G-21

5. SET-UP INSTRUCTIONS G-21

- 5.1 Precautions
- 5.2 Brush type Plug-In-&-Use Test Mode
- 5.3 Brushless amplifier set-up instructions (trapezoidal and sinusoidal)
- 5.4 Brushless amplifier with brush-type motor (trapezoidal only)

6. AMPLIFIER ADJUSTMENT (TUNING) PROCEDURE G-24

- 6.1 Command Signal
- 6.2 Feedback Elements
- 6.3 Current Loop Adjustments
- 6.4 Voltage or Velocity Loop Adjustments
- 6.5 Potentiometer adjustments
- 6.6 Test points for potentiometers

7. INVERTED INHIBIT INPUTS G-27

8. TROUBLE SHOOTING/FAULT CONDITIONS G-27

9. PRODUCT LABEL DESCRIPTION G-28

10. FACTORY HELP G-29

11. WARRANTY G-31

CAUTION: Exercise caution during maintenance and troubleshooting! Potentially lethal voltages exist within the amplifier and auxiliary assemblies. Only qualified technically trained personnel should service this equipment.

1. INTRODUCTION

1.1 Motion Control Systems

Motion control technology (sometimes also referred to as “robotics”) is used in industrial processes to move a certain load in a controlled fashion. These systems can use either pneumatic, hydraulic, or electromechanical actuation technology. The choice of the actuator type (i.e. the device that provides the power to move the load) is based on power, speed, precision, and cost requirements. Electromechanical systems are typically used in high precision, low power, and high-speed applications. Such systems are flexible (e.g. programmable), efficient, and very cost-effective. The actuators used in electromechanical systems generate power through the interaction of electromagnetic fields and create either rotary or linear motion. Typically a complete system consists of the following components:

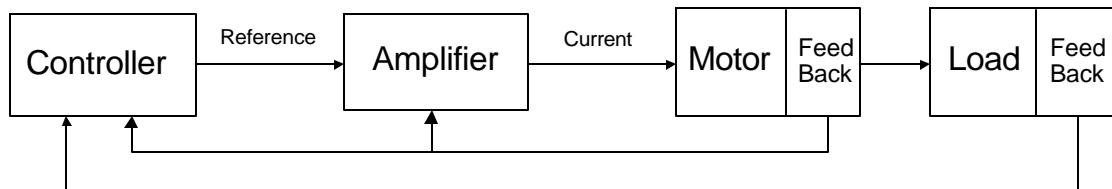

Figure 1 – Typical motion control system

The above figure shows the components typically used in a servo system (i.e. a feedback system used to control position, velocity, and/or acceleration). The controller contains the algorithms to close the desired servo loop and also handles machine interfacing (inputs/outputs, terminals, etc.). The amplifier represents the electronic power converter that drives the motor according to the controller reference signals. The motor (which can be of the brushed or brushless type, rotary or linear) is the actual electromagnetic actuator, which generates the forces required to move the load. Feedback elements are mounted on the motor and/or load in order to close the servo loop.

1.2 Servo Amplifiers

Servo amplifiers are used extensively in motion control systems where precise control of position and/or velocity is required. The amplifier basically translates the low-energy reference signals from the controller into high-energy signals (motor voltage and current). These reference signals can be either of an analog or digital nature. An analog ± 10 VDC signal is the most common. This signal can represent either a motor torque or velocity demand (see Amplifier Modes below).

1.2.1 Pulse Width Modulation (PWM)

Although there exist many ways to “amplify” electrical signals, pulse width modulation (or PWM) is by far the most efficient and cost-effective approach. At the basis of a PWM amplifier is a current control circuit that controls the output current by varying the duty cycle of the output power stage (fixed frequency, variable duty cycle). A typical setup is as follows (here for a single phase load):

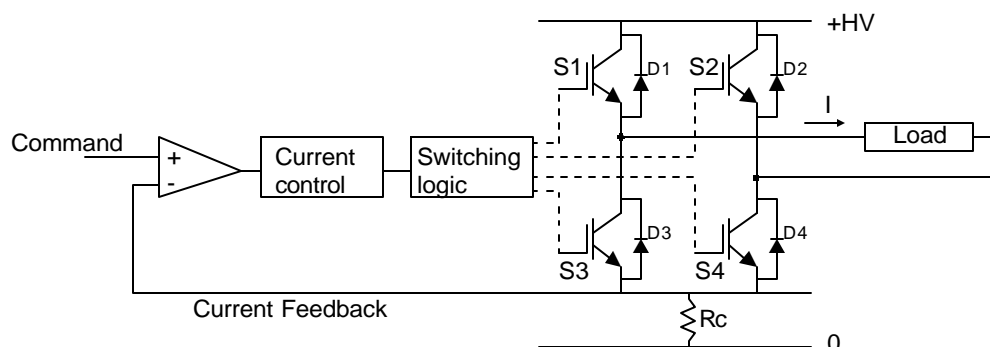

Figure 2 – PWM current control circuit

S1, S2, S3 and S4 are power devices (MOSFET or IGBT) that can be switched on or off. D1, D2, D3, and D4 are diodes, which guarantee current continuity. The bus voltage is depicted by +HV. The resistor R_c is used to measure the actual output current. For electric motors, the load is typically inductive (due to the windings used to generate electromagnetic fields). The current can be regulated in both directions (+ and -) by activating the appropriate switches. When switch S1 and S4 (or S2 and S3) are activated, current will flow in the positive (or negative) direction and increase. When switch S1 is off and switch S4 is on, (or S2 off and S3 on) current will flow in the positive (or negative) direction and decrease (via one of the diodes). The switch “ON”-time is determined by the difference between the current demand and the actual current. The current control circuit will compare both signals every time interval (typically 50 μ sec or less) and activate the switches accordingly (this is done by the switching logic circuit, which also performs basic protection functions). The picture below shows the relationship between the pulse width (ON-time) and the current pattern. Note that the current rise time depends on the bus voltage (+HV) and the load inductance. Therefore, certain minimum load inductance requirements are necessary depending on the bus voltage.

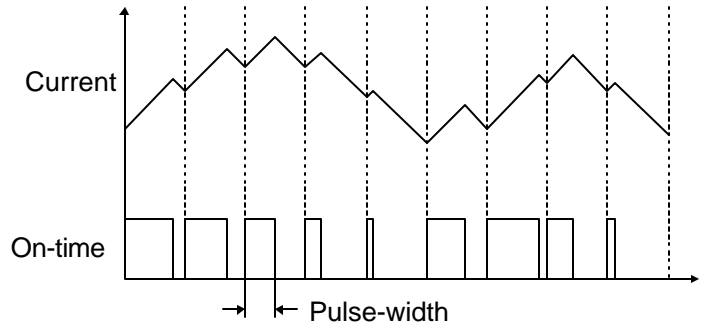

Figure 3 – Output current and duty cycle relationship

1.2.2 DC Brush Type Amplifiers

DC brush type amplifiers are designed for use with permanent magnet brushed DC motors (PMDC motors). The amplifier construction is basically as shown in figure 2 (single phase H-bridge). PMDC motors have a single winding (often called the armature) on the rotor, and permanent magnets on the stator (no field winding). Brushes and commutators maintain the optimum torque angle. The torque generated by a PMDC motor is proportional to the current, giving it excellent dynamic control capabilities in motion control systems.

Brushed DC amplifiers can also be used to control current in other inductive loads such as voice coil actuators, magnetic bearings, etc.

1.2.3 Brushless Amplifiers

Brushless amplifiers are used with brushless servo motors. These motors typically have a three-phase winding on the stator and permanent magnets on the rotor. Brushless motors require commutation feedback for proper operation (the commutators and brushes perform this “commutation” function in brush type motors). This feedback consists of rotor magnetic field orientation information, which can be supplied either by magnetic field sensors (Hall Effect sensors) or position sensors (encoder or resolver). Brushless motors have better power density ratings than brushed motors because heat is generated in the stator (shorter thermal path to the outside environment), not on the rotor. Also, the absence of brushes allows them to be used in any environment. A typical system configuration is as follows:

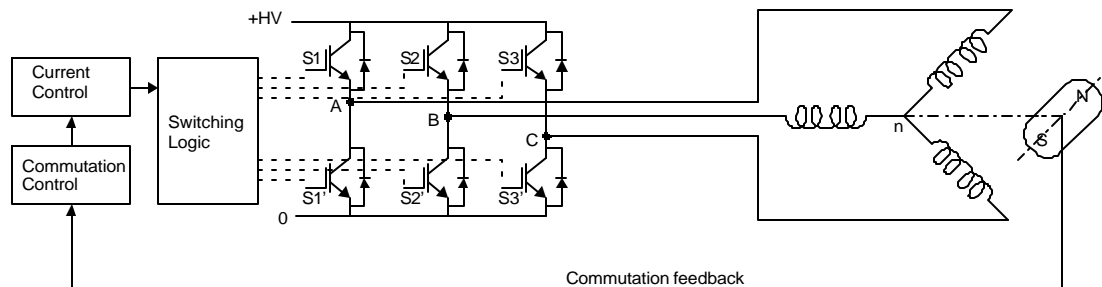

Figure 4 – Brushless servo system

DC Brushless Amplifiers (a.k.a. trapezoidal, 6-step)

DC brushless amplifiers use Hall Effect sensor signals for commutation feedback. The Hall Effect sensors (typically three) are built into the motor to detect the position of the rotor magnetic field. These sensors are mounted such that they each generate a square wave with 120-degree phase difference, over one electrical cycle of the motor. The amplifier drives two of the three motor phases with DC current during each specific Hall sensor state:

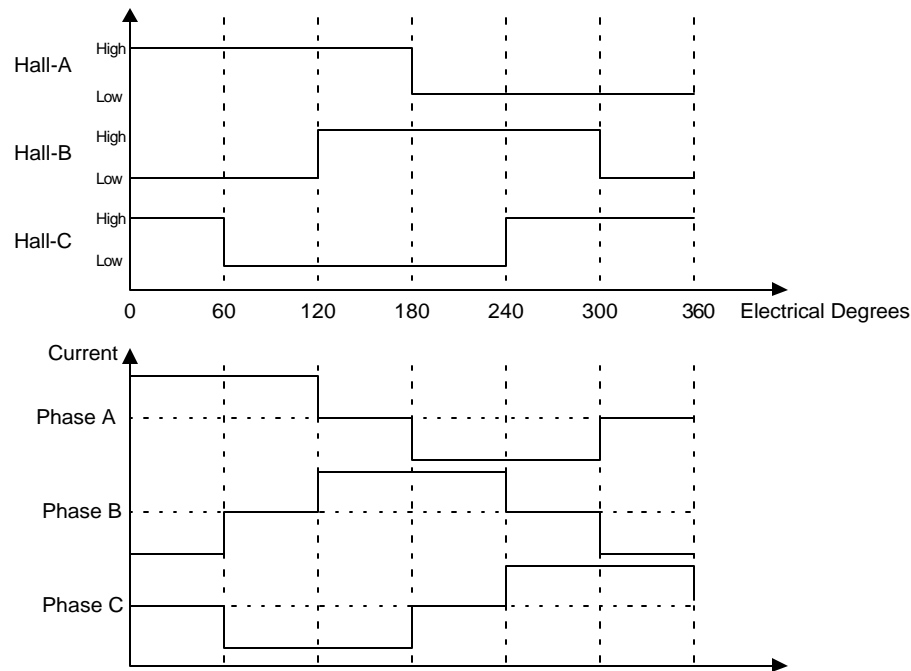

Figure 5 – Hall sensor based commutation

This commutation technique results in a very cost-effective amplifier. When used with motors with sinusoidal back-EMF, the torque ripple is about 13.4%. The average torque is 5% lower compared to a sinusoidal (or AC brushless) system, the peak torque however is 10% higher.

AC Brushless Amplifiers (a.k.a. sinusoidal, sine wave)

AC brushless amplifiers use encoder or resolver signals for commutation feedback. The amplifier drives the motor with sinusoidal currents, resulting in smooth motion (no torque ripple). The amplifier is more complex since it needs to accept high-resolution position feedback. Such amplifiers use a micro-controller implementation for the sinusoidal commutation.

When encoder feedback information is used for commutation, Hall Effect sensors are still needed for startup since the encoder provides only incremental position information. Resolvers provide absolute position information and therefore no additional sensors are required.

The commutation function can also be implemented in the motion controller. In such case, the amplifier merely amplifies the controller signals (2 analog sinusoidal signals that represent 2 of the 3 motor phase currents). The amplifier creates the third motor phase current (sum of the three currents must be zero). No position feedback needs to be wired into the amplifier. The motor current amplitude (Amperes) is proportional to the reference signal amplitude (Volts). The reference signal frequency depends on the motor velocity and the motor pole count. The phase angle is adjusted to obtain maximum torque. Amplifiers accepting 2 sinusoidal reference signals are sometimes also referred to as “non-commutating” or U-V amplifiers.

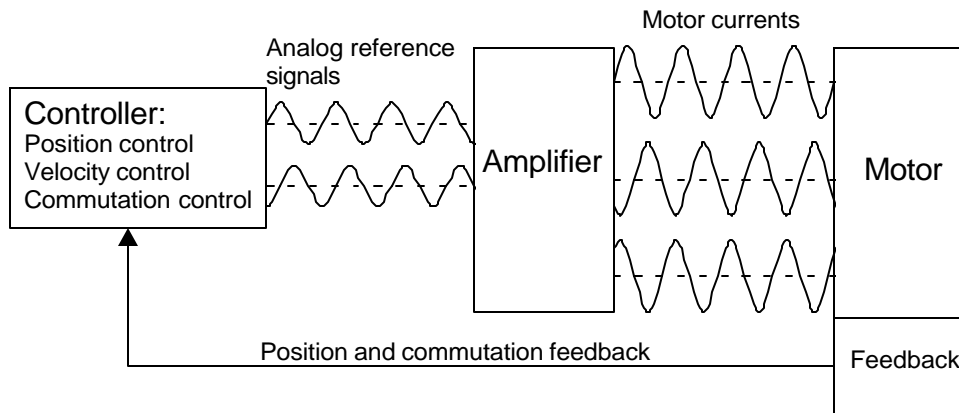

Figure 6 – Controller-based commutation

1.3 Amplifier Modes

Servo amplifiers can operate in most of the following modes:

AMPLIFIER MODE	CONTROLLED VARIABLE	FEEDBACK SOURCE
Open-loop Mode	Motor voltage	Duty cycle (internal)
Voltage Mode	Motor voltage	Voltage (internal)
IR Compensation Mode	Motor voltage	Voltage and current (internal)
Tachometer Velocity Mode	Motor speed	Tachometer
Hall Velocity Mode		Hall Sensors
Encoder Velocity Mode		Encoder
Current (torque) Mode	Motor current	Current (internal)
Analog Position Mode	Motor position	Potentiometer

The “controlled variable” means the physical parameter controlled by the input reference signal (+/-10 VDC).

- *Open-Loop Mode*

In this mode the input reference signal commands a proportional motor voltage (by changing the duty cycle of the output power stage). This mode is not a closed loop configuration (unlike the other modes described); therefore the average output voltage is also a function of the power-supply voltage.

- *Voltage Mode*

In voltage mode, the input reference signal commands a proportional motor voltage regardless of power supply voltage variations. This mode is recommended for velocity control when velocity feedback is unavailable and load variances are small.

- *IR Compensation Mode*

If in voltage mode there is a load torque variation, the motor current will vary, as torque is proportional to motor current. Hence, the motor terminal voltage will be reduced by the voltage drop over the motor winding resistance (IR), resulting in

a speed reduction. Thus, motor speed - which is proportional to motor voltage (terminal voltage minus IR drop) - varies with the load torque.

In order to compensate for the internal motor voltage drop, a voltage proportional to motor current can be added to the output voltage. An internal resistor adjusts the amount of compensation. Use caution when adjusting the IR compensation level. If the feedback voltage is high enough to cause a rise in motor voltage with increased motor current, instability occurs. Such result is due to the fact that increased voltage increases motor speed and thus load current which, in turn, increases motor voltage. If a great deal of motor torque change is anticipated, it may be wise to consider the addition of a speed sensor to the motor (e.g. tachometer, encoder, etc.).

- *Tachometer Velocity Mode*

The addition of a DC tachometer to the motor shaft produces a voltage proportional to speed. With this addition, the tachometer output voltage replaces the motor terminal voltage as the controlled variable. Since this voltage is proportional to the motor speed, this operating mode truly controls motor speed in a closed loop fashion.

- *Hall Velocity Mode*

The frequency of Hall sensors is proportional to the motor speed. In most brushless amplifier series, an internal circuit decodes velocity information from the motor mounted Hall sensors. This analog signal is available for closed loop velocity control. This mode does not provide good velocity control at low speeds (below 300 rpm for a 6-pole motor, 600 rpm for a 4-pole motor, or 900 rpm for a 2-pole motor) since the resolution of Hall sensor signals is not very high.

- *Encoder Velocity Mode*

The frequency of a motor mounted encoder is proportional to the motor speed. An internal circuit can decode velocity information from such encoder feedback. This analog signal is available for closed loop velocity control. Since the resolution of an encoder is much higher than of Hall Effect sensors, much better low speed regulation can be obtained.

- *Current (or Torque) Mode*

The current mode produces a torque output from the motor proportional to the input reference signal. Motor output torque is proportional to the motor current. Torque mode is recommended if the servo amplifier is used with a digital position controller (under this condition, a movement of the motor shaft from the desired position causes a large correcting torque, or "stiffness"). Therefore, this mode may produce a "run away" condition if operated without a digital position controller.

- *Analog Position Loop Mode*

In this mode the feedback device is an analog potentiometer mechanically tied to the positioned object, thus providing position feedback. The wiper of the potentiometer is connected to one of the differential input terminals (-REF). The command is an analog signal, which is connected to the other differential input terminal. It is recommended to use a tachometer to close the velocity loop. The input reference gain can be increased for the analog position mode by ordering the -ANP extension. Example: 12A8X-ANP. The following figure is a typical wiring diagram of the analog position mode:

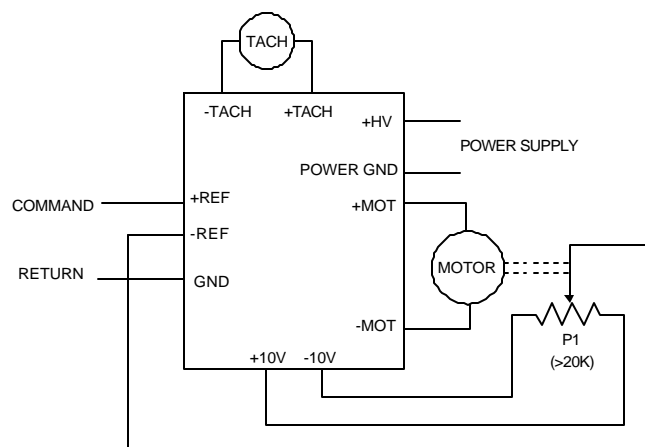

Figure 7 – Analog Position Loop Mode

2. COMPONENT SELECTION

2.1 Motor Type

The type of motor used depends on the application characteristics. Brushed DC motors are cost-effective, simple to use and install, and provide high power density. Drawbacks are brush wear and arcing (explosive environments). Brushless motors provide the same advantages as brushed DC motors. The absence of brushes reduces maintenance and allows them to be used in any type of environment. Brushless motors may require more wiring due to the commutation feedback requirements.

Determine motor voltage and current requirements, based on the maximum velocity and torque. Torque and velocity can be derived from the application move profiles. Both maximum torque and RMS (Root Mean Square) torque need to be calculated. RMS torque can be calculated by plotting torque versus time for one move cycle.

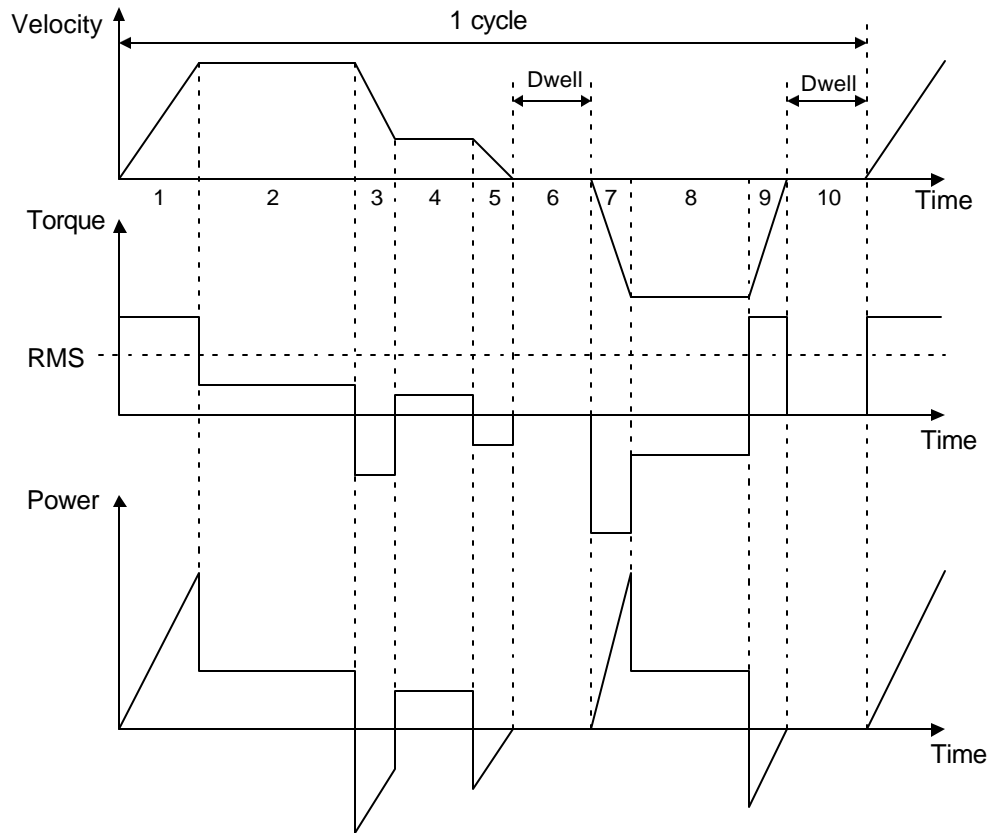

Figure 8 – Torque, velocity and power curves

RMS torque is calculated as follows:

$$T_{RMS} = \sqrt{\frac{\sum_i T_i^2 * t_i}{\sum_i t_i}}$$

Here T_i is the torque and t_i the time during segment i . In the case of a vertical application, make sure to include the torque required to overcome gravity. In general, the motor voltage is proportional to the motor speed and the motor current is proportional to the motor shaft torque. Linear motors exhibit the same behavior, except that in their case force is proportional to current. These relationships are described by the following equations:

$$V_t = I_m * R_m + E$$

$$E = K_e * S_m$$

$$T = K_t * I_m \quad \text{for rotary motors or}$$

$$F = K_f * I_m \quad \text{for linear motors}$$

With:

V_t	Terminal Voltage [V]
I_m	Motor Current [A]
R_m	Motor Winding Resistance [Ω]
E	Back-EMF Voltage [V]
T	Motor Torque [Nm or lb.-in]
F	Motor Force [N or lb.]
K_t	Motor Torque Constant [Nm/A or lb.-in/A]
K_f	Motor Force Constant [N/A or lb./A]
K_e	Voltage Constant [V/Krpm or V/m/s]
S_m	Motor Speed [rpm or m/s]

The motor manufacturer's data sheets contain K_t (or K_f) and K_e constants. Pay special attention to the units used (metric vs. English) and the amplitude specifications (peak-to-peak vs. RMS, phase-to-phase vs. phase-to-neutral).

The maximum motor terminal voltage and current can be calculated from the above equations. For example, a motor with a $K_e = 10\text{V/Krpm}$ and required speed of 3000 rpm would require 30V to operate. In this calculation the IR term (voltage drop across motor winding resistance) is disregarded.

Maximum current is maximum torque divided by K_t . For example, a motor with a $K_t = 0.5\text{ Nm/A}$ and maximum torque of 5 Nm would require 10 Amps of current. Continuous current is RMS torque divided by K_t .

In the above equations, the motor inductance is neglected. In brushless systems, the voltage drop caused by the motor inductance can be significant. This is the case in high-speed applications, if motors with high inductance and high pole count are used. Please use the following equation to determine motor terminal voltage (must be interpreted as a vector):

$$V_t = (R_m + j * \omega * L) * I_m + E$$

Where:	L	phase-to-phase motor inductance [Henry]
	ω	maximum motor current frequency [rad/s]

2.2 Amplifier

The amplifier voltage and current ratings are determined from the maximum voltage and the maximum and continuous motor current. It is recommended to select an amplifier with a voltage rating of at least 20% higher than the maximum voltage to allow for regenerative operation and power supply variations. The amplifier peak (and continuous) current rating should exceed the maximum (and continuous) motor current requirements.

2.3 Power Supply

It is recommended to select a power supply voltage that is about 10 to 50% higher than the maximum required voltage for the application. This percentage is to account for the variances in K_t , K_e and losses in the system external to the amplifier. The selected margin depends on the system parameter variations. Sometimes a power supply is not available with the required voltage. In these cases it is necessary to choose a higher value. Make sure not to select a supply voltage that could cause a mechanical over-speed in the event of an amplifier malfunction or a runaway condition. Caution: brushed motors may have voltage limitations due to the mechanical commutators. Consult the motor manufacturer's data sheets.

The average DC power supply current is not the same as the motor current! See figure 9 below.

The power supply current is a pulsed DC current: when the MOSFET switch is on, it equals the motor current; when the MOSFET is off it is zero. Therefore, the power supply current is a function of the PWM duty-cycle and the motor

current, e.g. 30% duty cycle and 12 Amps motor current will result in 4 amps power supply current. 30% duty cycle also means that the average motor voltage is 30% of the DC bus voltage. Power supply power is approximately equal to amplifier output power plus 3 to 5%.

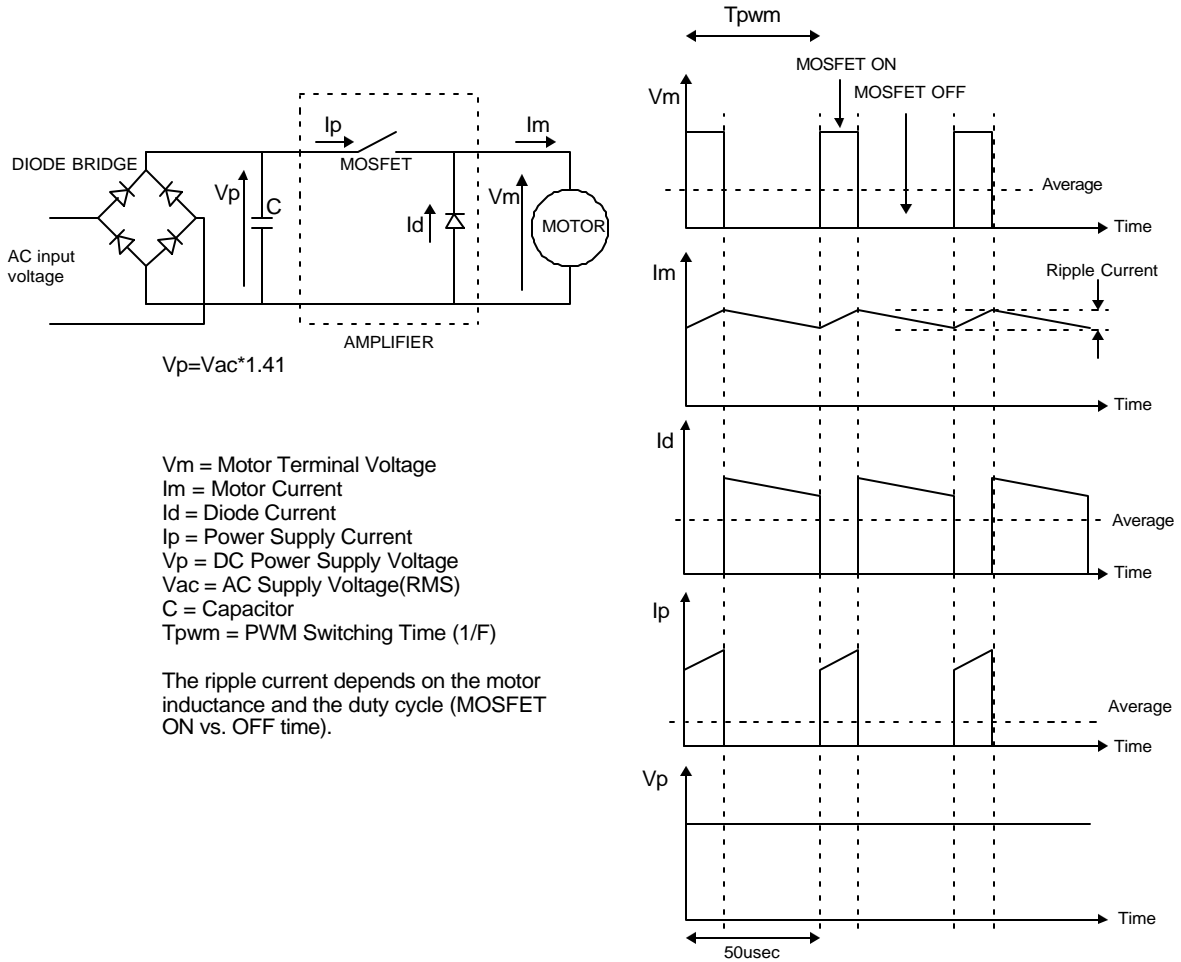

Figure 9 – Unregulated power supply current

2.4 Four Quadrant Regenerative Operation

During motor deceleration or a downward motion of the motor load, conversion of the system's mechanical energy (kinetic and potential) will be regenerated via the servo amplifier or drive back onto the supply bus in the form of electrical energy.

This regenerative process can charge the capacitor in the supply bus to potentially dangerous voltages or voltages that may cause an amplifier over-voltage shutdown condition. Consequently, power supplies should have sufficient capacitance to absorb this energy without causing an over-voltage fault. For applications with extremely large inertial loads, use of a "shunt regulator" may be necessary to dissipate the kinetic and potential energy of the load. The shunt regulator is connected to the DC bus to monitor the voltage. When a preset trip voltage is reached, a power

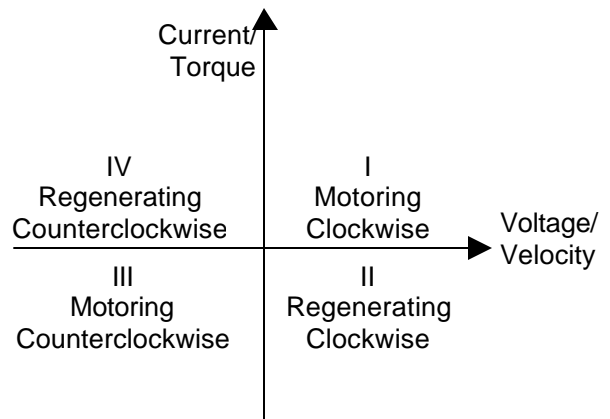

Figure 10-Four-quadrant operation

resistor R is connected across the DC bus by the shunt regulator circuit to discharge the bus capacitor. The electric energy, stored in the capacitor, is thereby transformed into heat (I^2R).

The amount of energy stored on the bus can be determined through a simple energy balance equation.

$$E_o = E_f$$

These energy terms can be broken down into the approximate mechanical and electrical terms. Note: use the metric (kg-m-s) system of units for calculation.

Energy stored in a capacitor:

$$E_c = \frac{1}{2} CV^2$$

Rotational mechanical energy (kinetic):

$$E_r = \frac{1}{2} J\omega^2$$

Potential mechanical energy (gravity):

$$E_p = mgh$$

During regeneration the kinetic and potential energy will be stored in the power supply's capacitor. To determine the final bus voltage following a regenerative event, the following equation may be used for most requirements (see below for variable definitions):

$$(E_c + E_r + E_p)_0 = (E_c + E_r + E_p)_f$$

$$\frac{1}{2} CV_{nom}^2 + \frac{1}{2} J\mathbf{v}_0^2 + mgh_0 = \frac{1}{2} CV_f^2 + \frac{1}{2} J\mathbf{v}_f^2 + mgh_f$$

Which simplifies to:

$$V_f = \sqrt{V_{nom}^2 + \frac{J}{C} (\mathbf{v}_0^2 - \mathbf{v}_f^2) + \frac{2mg(h_0 - h_f)}{C}}$$

The above equations are best suited for typical systems during the deceleration (braking). The following equations are more suited for vertical applications (see below for variable definitions):

Determination of bus voltage using numerical integration:

In order to determine the bus voltage as a function of time, the above equation can be numerically integrated over small increments of time (dt). Keep in mind, however, that any current draw on the voltage supply will reduce the total energy as:

$$dE_{tot} = dE_c + dE_r + dE_p + VI_{draw}dt$$

Or, for small increments of time, dt:

$$V_{t2}(t) = \sqrt{V_{t1}^2 + \frac{J}{C} (\mathbf{v}_{t1}^2 - \mathbf{v}_{t2}^2) + \frac{2mg}{C} (h_{t1} - h_{t2}) - \frac{2V_{t1}I_{draw}}{C} dt}$$

Where:

$$t_2 = t_1 + dt$$

Variables:

E	Energy	(joules)
C	Capacitance	(F)
V	Voltage	(V)
L	Inductance	(H)
I	Current	(A)
J	Inertia	(kg-m ²)
?	Angular velocity	(rad/sec)
m	Mass	(kg)
v	Linear velocity	(m/s)
g	Gravitational Acceleration	(9.81m/s ²)
h	Vertical height	(m)
t	time	(sec)

Subscripts:

0	Initial state
f	Final state
t1	State at time t ₁
t2	State at time t ₂
nom	Nominal

The new bus voltage calculated using either set of equations must be below the power supply capacitance voltage rating and the over-voltage limit. If this is not the case, a shunt regulator is necessary. A shunt regulator is sized in the same way as a motor or amplifier i.e. continuous and RMS power dissipation must be determined. The power dissipation requirements can be calculated from the application move profile (see figure 8).